



# INSTALLATION INSTRUCTIONS

Accessory  
XM RADIO SYSTEM

Application  
2013 ILX

Publications No.  
**BII 13548**  
Issue Date  
**MAY 2012**

## PARTS LIST

**XM Radio Attachment Kit**  
**P/N 08B15-TX6-200**

Bus cable

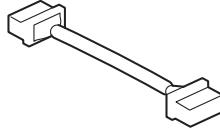

2 Brackets

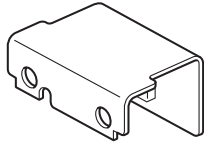

6 Washer bolts



4 Wire ties

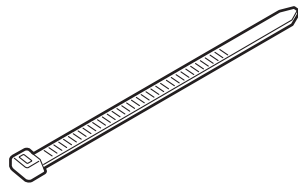

4 Urethane tapes

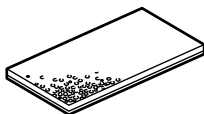

Cover seal

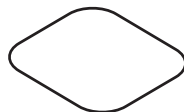

Clip

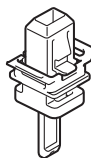

Aluminum tape

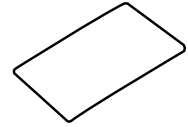

Accessory User's Information Manual

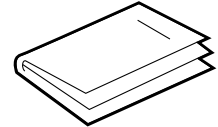

**XM Antenna Kit (sold separately)**  
**P/N 08A15-0J1-100**

Antenna

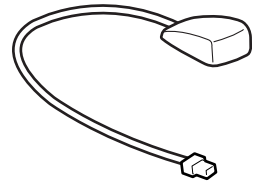

**Unit Kit (sold separately)**  
**P/N 08A15-TR0-100**

XM radio unit

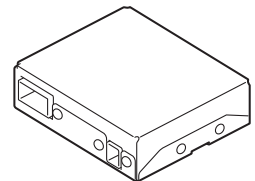

**2-Port Subharness Kit (sold separately)**  
**P/N 08A31-0F1-000**

2-Port subharness

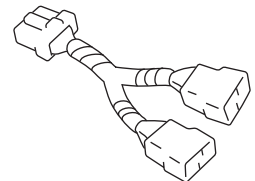

## TOOLS AND SUPPLIES REQUIRED

Phillips screwdriver  
Flat-tip screwdriver  
Shop towel  
Scissors  
Ratchet  
8 mm and 10 mm Sockets  
Isopropyl alcohol  
Tape measure  
Diagonal cutters  
Tape

*The following tools are available through the Honda Tool and Equipment Program. On the iN, click on: Service > Service Bay > Tool and Equipment Program, then enter the number under "Search". Or, call 888-424-6857.*

Trim Tool Set (T/N SOJATP2014)

Plastic Trim Tool (T/N SILTRIMTL10)

## Illustration of the XM Radio System in the Vehicle

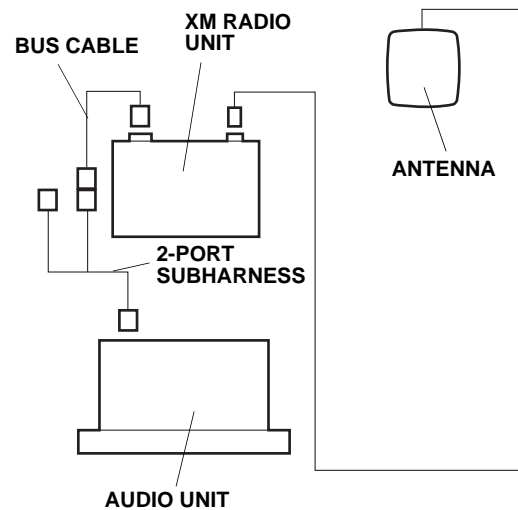
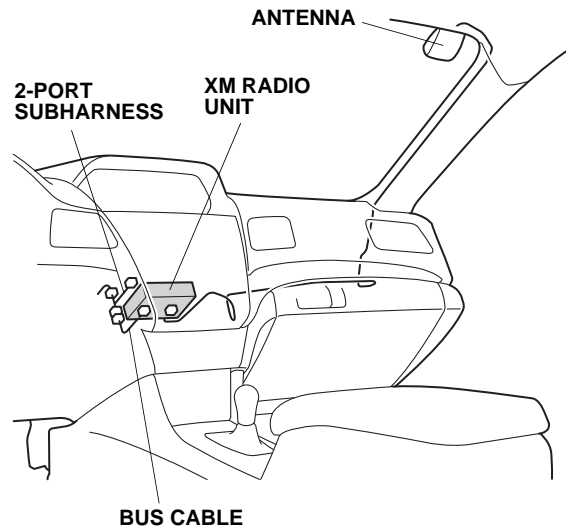

## INSTALLATION

**Client Information:** The information in this installation instruction is intended for use only by skilled technicians who have the proper tools, equipment, and training to correctly and safely add equipment to your vehicle. These procedures should not be attempted by “do-it-yourselfers.”

1. Disconnect the negative cable from the battery.
2. Remove the passenger’s sunvisor holder by turning it 45° in the counterclockwise direction.

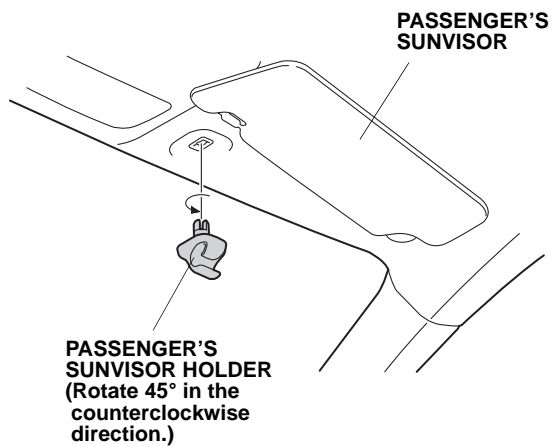

3. Remove the passenger’s sunvisor:
  - Pivot the right sunvisor downward.
  - Wrap tape around the tip of flat-tip screwdriver.
  - Locate the slot in the bracket cover, and insert the flat-tip screwdriver into the slot. Push in and hold the retaining tab.
  - While holding the retaining tab, push up on the sunvisor and rotate it toward the door.

**NOTE:** If the retaining tab did not stay pushed in, return the sunvisor to its original position and repeat this step.

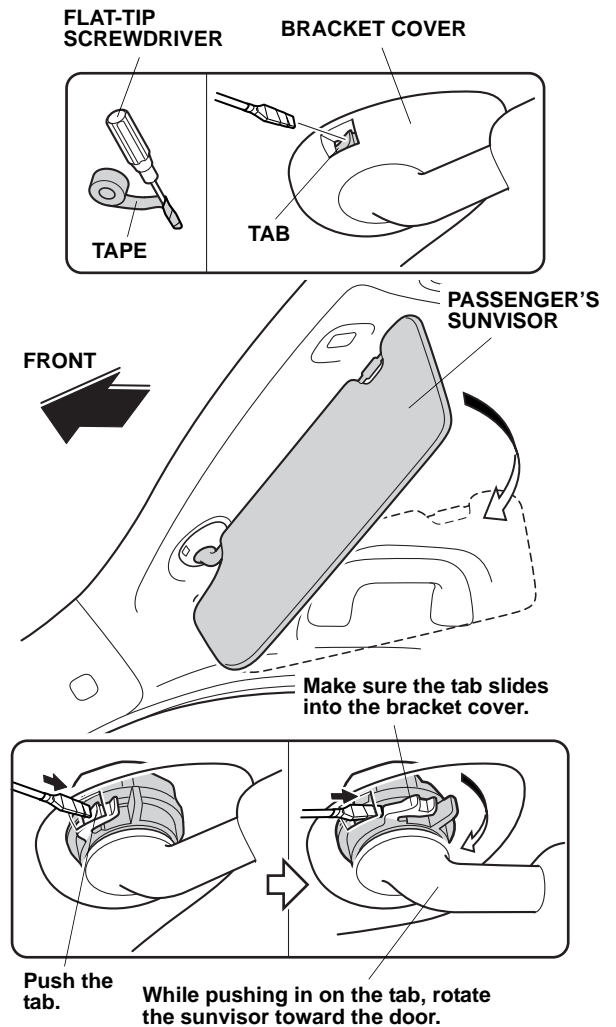

- Unplug the vehicle connector, and remove the passenger's sunvisor.

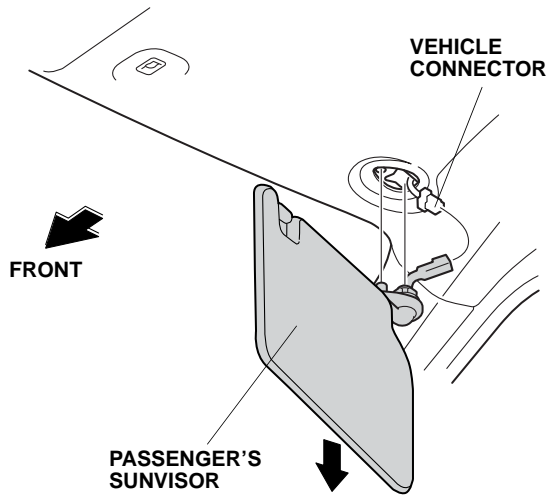

- To prevent clips from falling into the body panel area, carefully insert a shop towel between the passenger's A-pillar and the passenger's A-pillar trim.

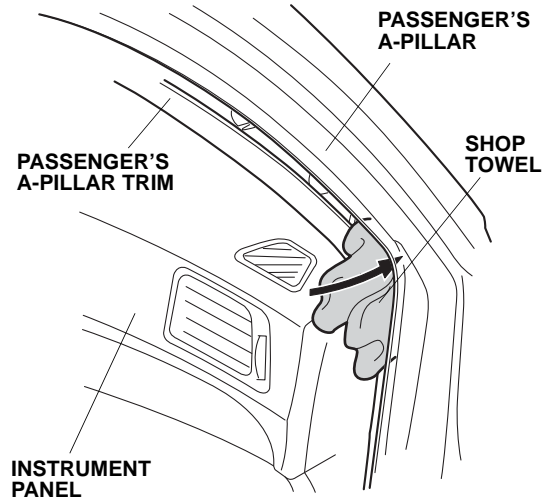

4. Remove the passenger's A-pillar trim.
  - Pull away the passenger's door opening seal from the A-pillar trim.
  - Gently pull the A-pillar trim away from the A-pillar to release the three clips.

- Slide the passenger's A-pillar trim upward, and remove the passenger's A-pillar trim.
- Remove the shop towel and any clips.

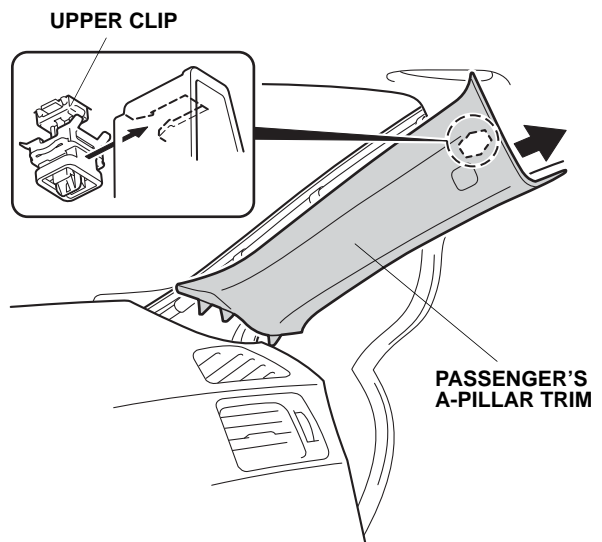
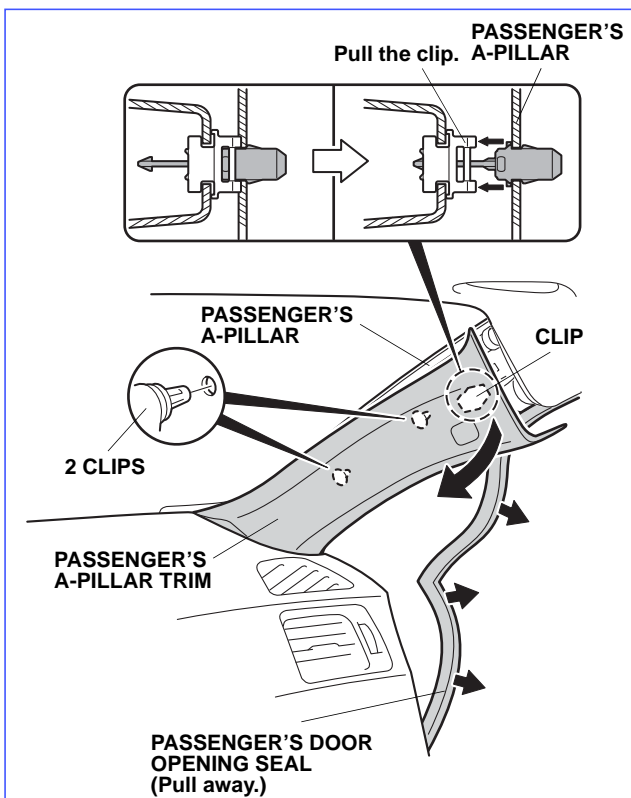

- Remove the remaining upper clip from the passenger's A-pillar.

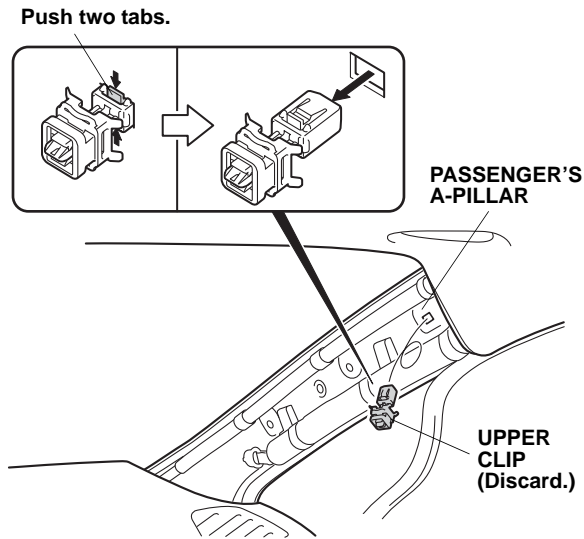

- Install the new clip (supplied) to the passenger's A-pillar trim.  
NOTE: When reinstalling the A-pillar trim, refer to the service manual for the correct overlap procedure.

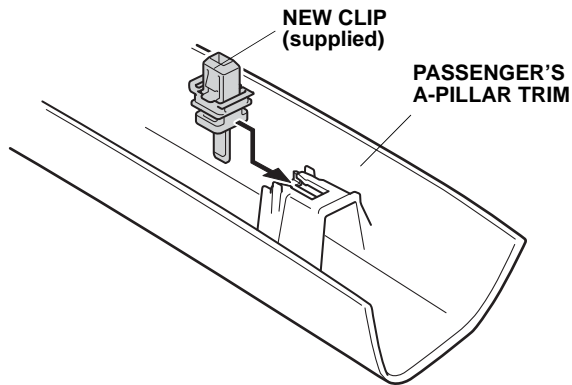

- Pull away the door seal from around the passenger's dashboard side cover.

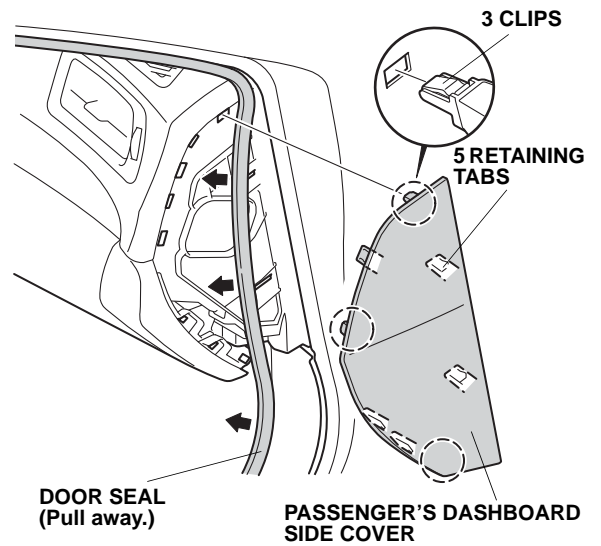

- Remove the passenger's dashboard side cover (three clips and five retaining tabs).
- Open the glove box. Remove the passenger's dashboard trim (six clips).

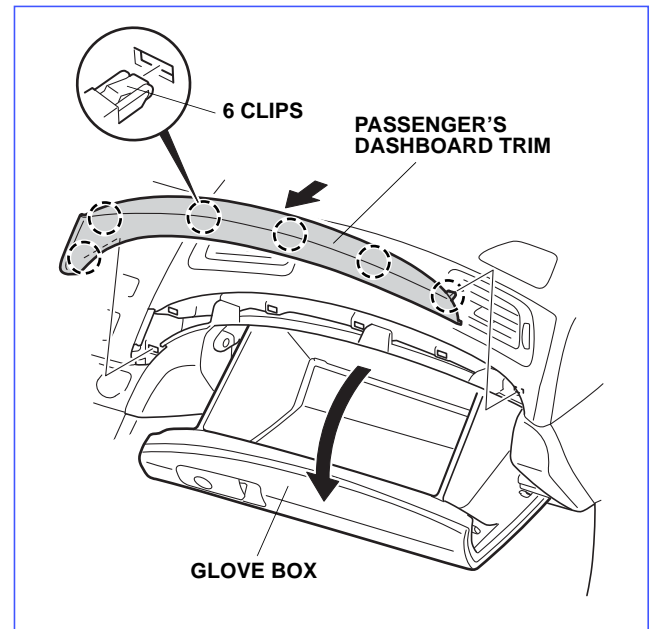

- Close the glove box.

11. Remove the passenger's dashboard undercover.
  - Release three clips and two pins, then pull the passenger's dashboard undercover toward you.
  - Remove the bulb socket, and remove the passenger's dashboard under cover.

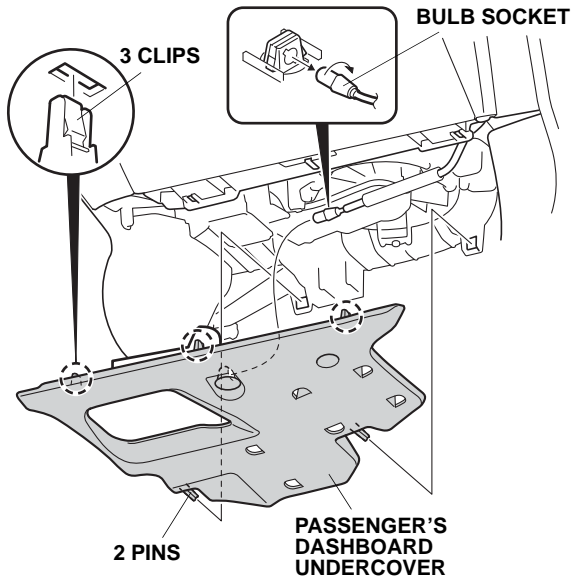

12. Remove the driver's dashboard lower cover (nine clips, and unplug the vehicle connector).

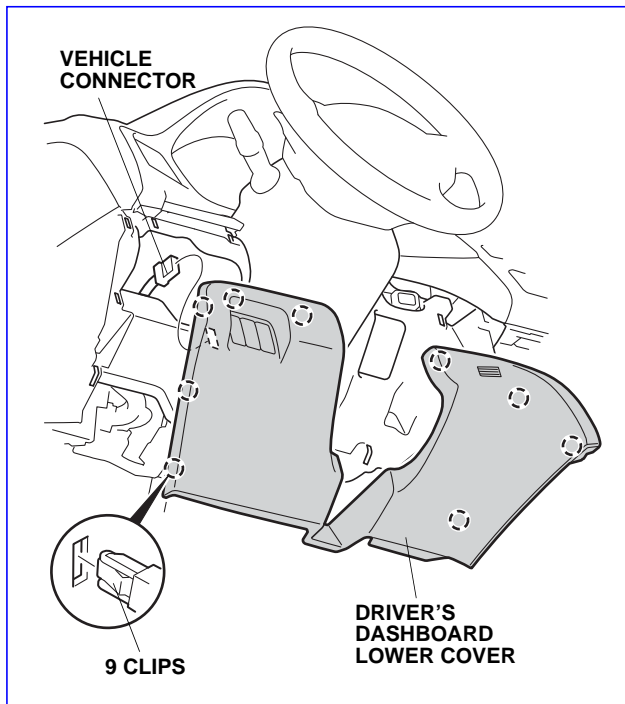

13. Remove the driver's inner dashboard trim (four clips and unplug the vehicle connector).

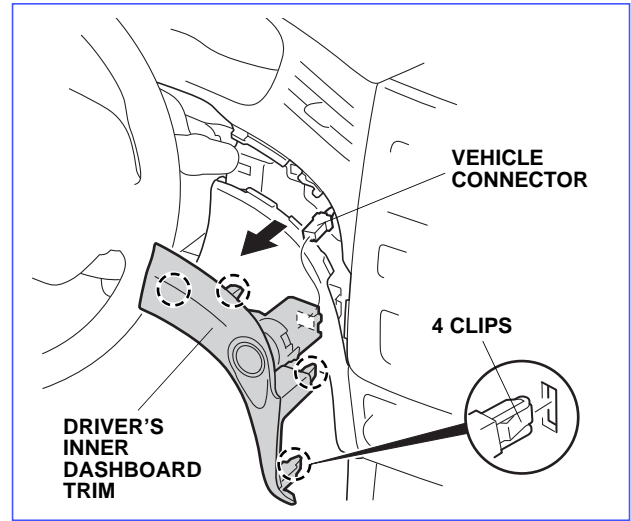

14. Move the shift lever to the N (neutral) position. Apply masking tape to the areas shown.

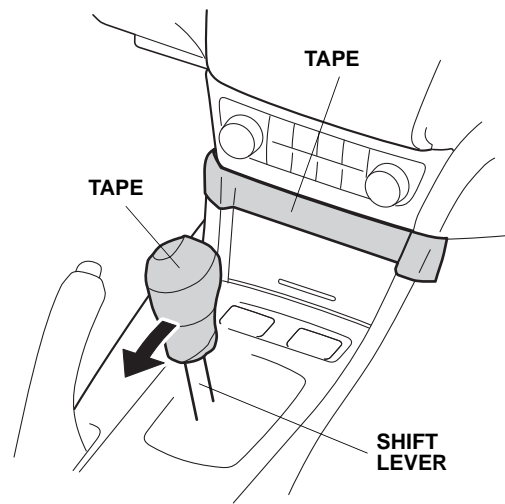

15. Remove the heater control panel (one self-tapping screw, three clips, and three retaining tabs).

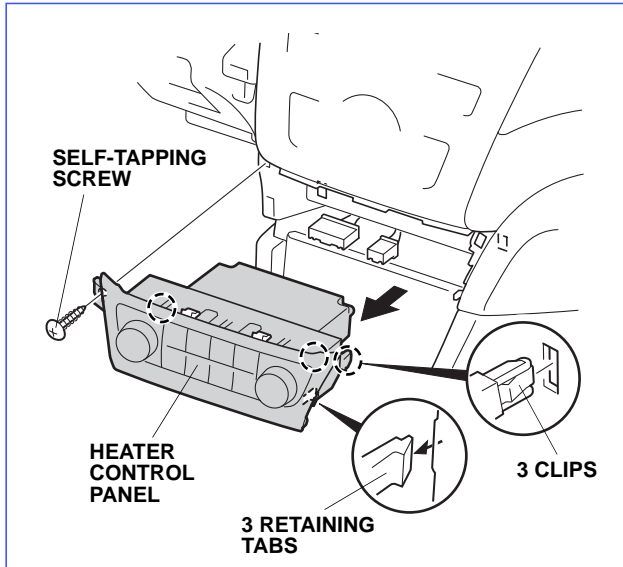

16. Remove the two bolts from the bottom of the glove box.

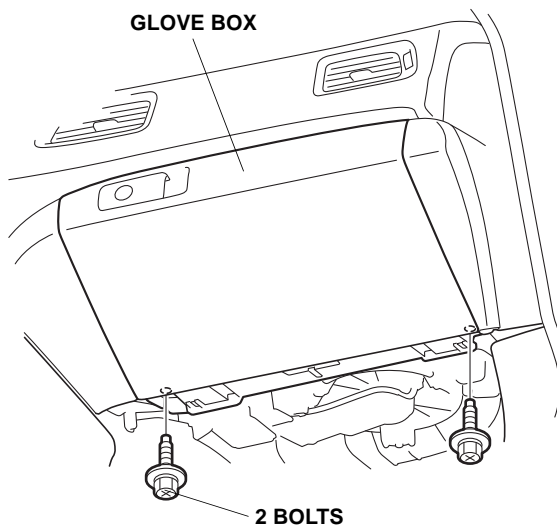

17. Remove the glove box (three self-tapping screws and unplug the vehicle connectors).

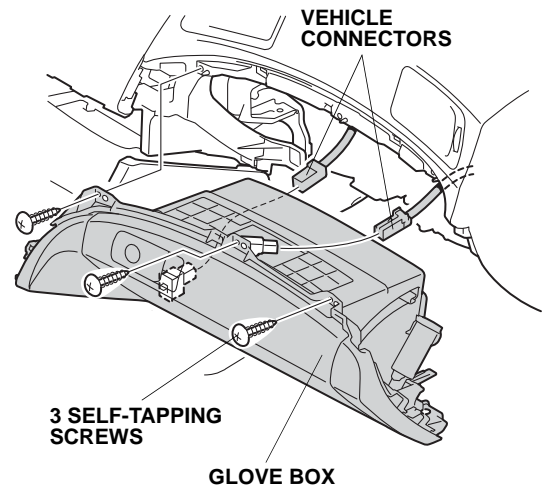

18. Remove the two bolts, then remove the center panel (eight clips and unplug the vehicle connectors).

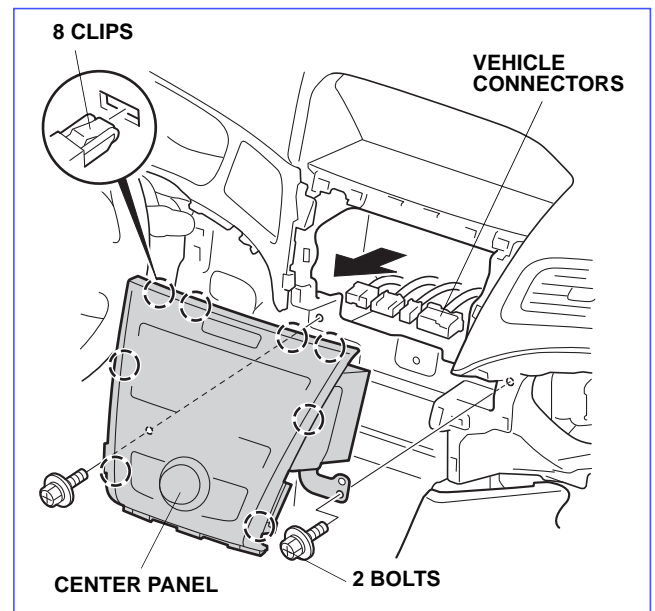

19. Install the two brackets to the audio unit with two washer bolts. Do not tighten the washer bolts at this time.

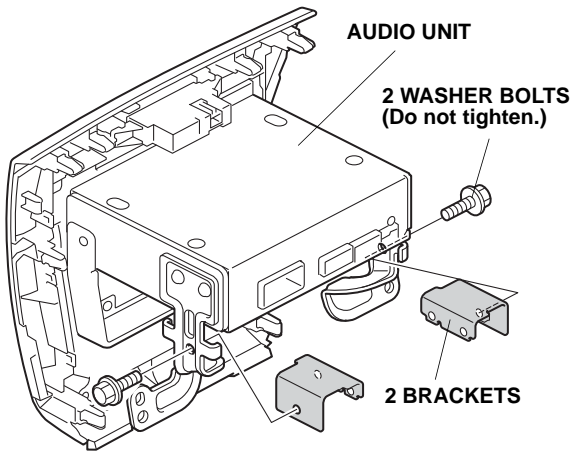

20. Install the XM radio unit onto the brackets on the audio unit with four washer bolts.

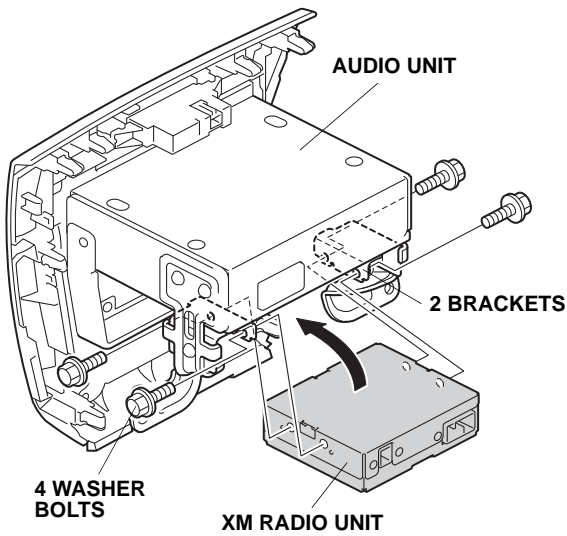

21. Tighten the two washer bolts installed in step 19.

22. Using scissors, cut one urethane tape in half.

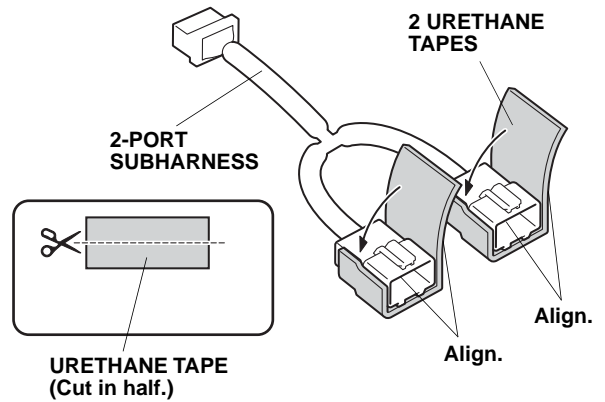

23. Wrap the cut pieces of urethane tape around the 2-port subharness connectors as shown.
24. Plug the bus cable connector into the XM radio unit.

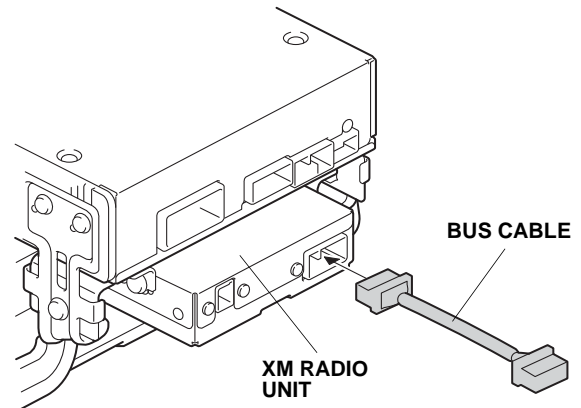



25. Plug the 2-port subharness into the audio unit connector and into the bus cable connector.

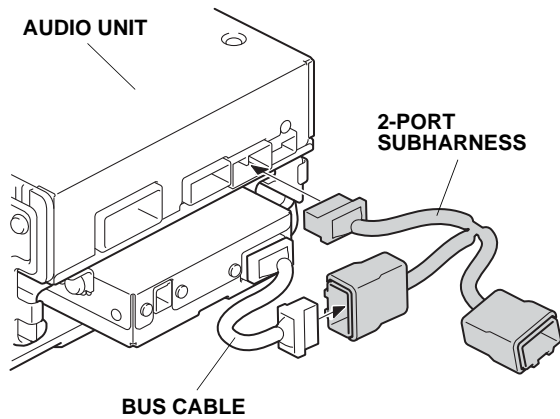

26. Using scissors, cut three urethane tapes in half.

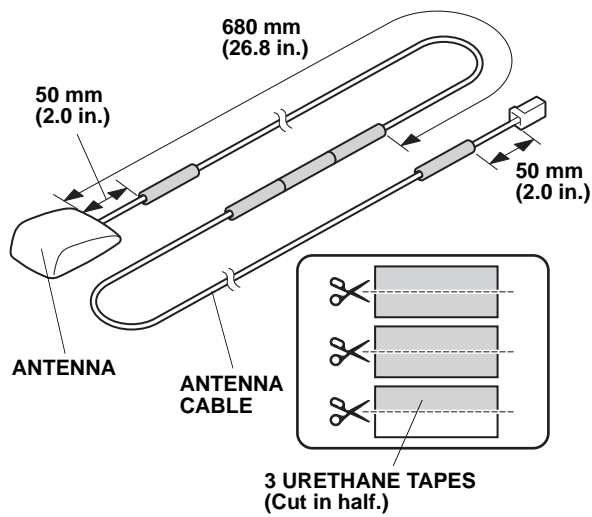

27. Wrap five of the cut pieces of urethane tape around the antenna cable at the measurements shown.

28. On the passenger's side of the vehicle, use isopropyl alcohol on a shop towel to clean the top inside corner of the windshield at the location shown.

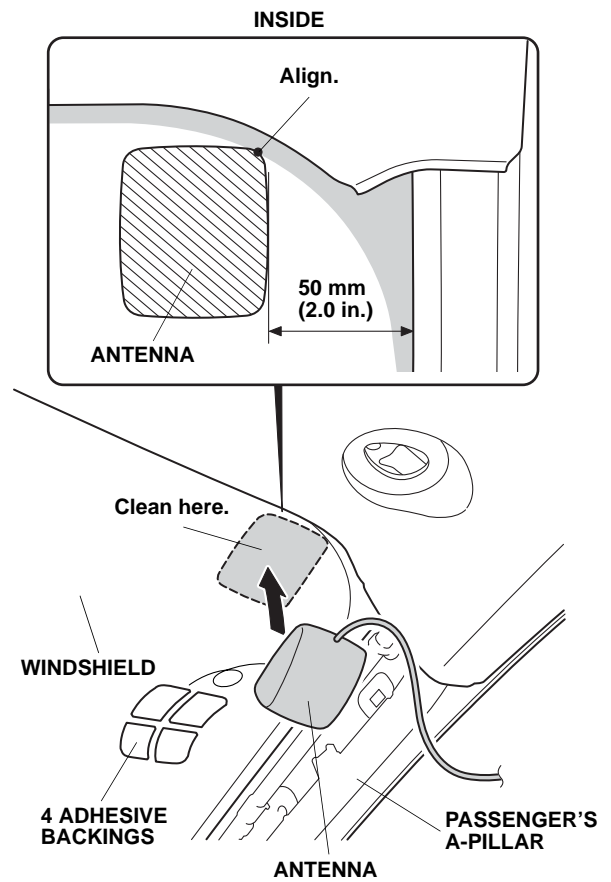

29. Remove the four adhesive backings from the antenna, and attach the antenna to the windshield at the measurement shown. Apply firm pressure to the antenna for at least 30 seconds.

30. Using isopropyl alcohol on a shop towel, clean the outside of the windshield over the antenna area.

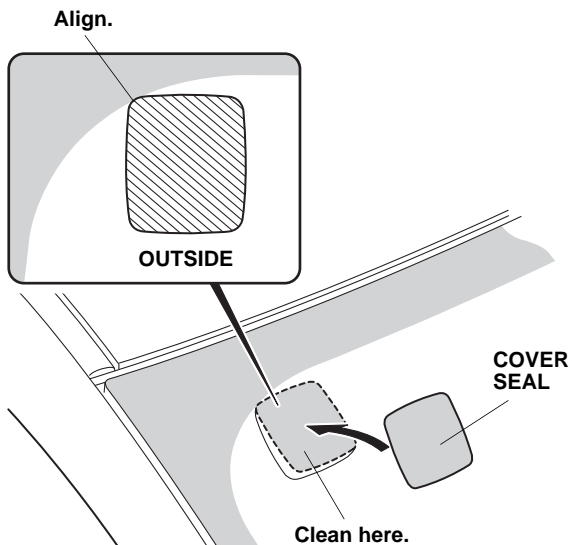

31. Remove the adhesive backing from the cover seal, position it over the antenna, and attach it to the outside of the windshield.
32. Using scissors, cut the aluminum tape into four pieces.

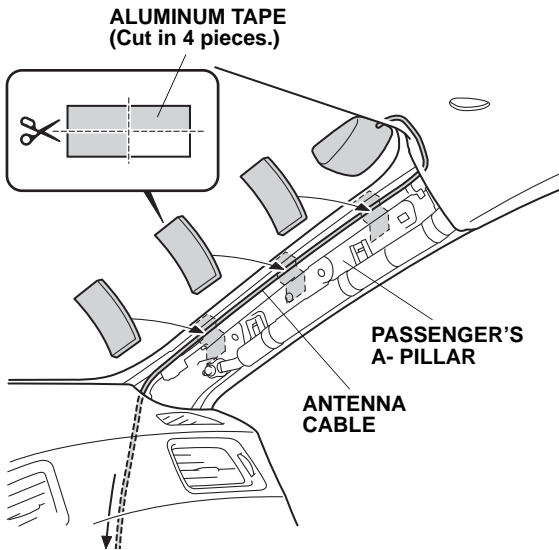

33. Route the antenna cable along the passenger's A-pillar. Using isopropyl alcohol on shop towel, clean the A-pillar where the aluminum tape will attach. Using three pieces of aluminum tape, secure the antenna cable to the A-pillar in the areas shown. **NOTE:** Be careful not to attach the aluminum tape over the holes in the A-pillar.

34. Route the antenna cable down behind the dashboard.

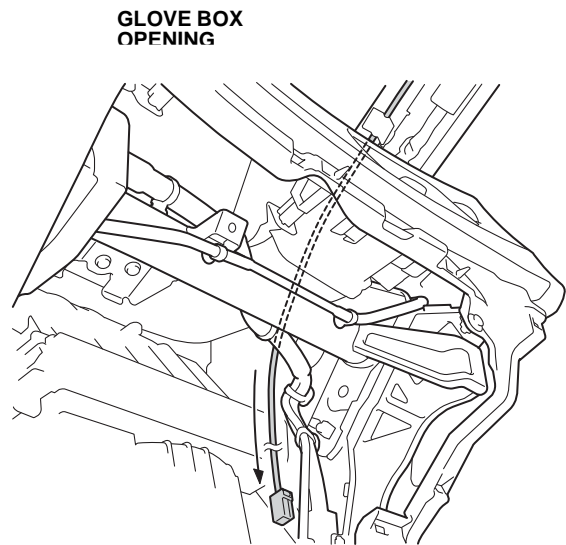

35. Using one wire tie, secure the antenna cable to the vehicle harness.

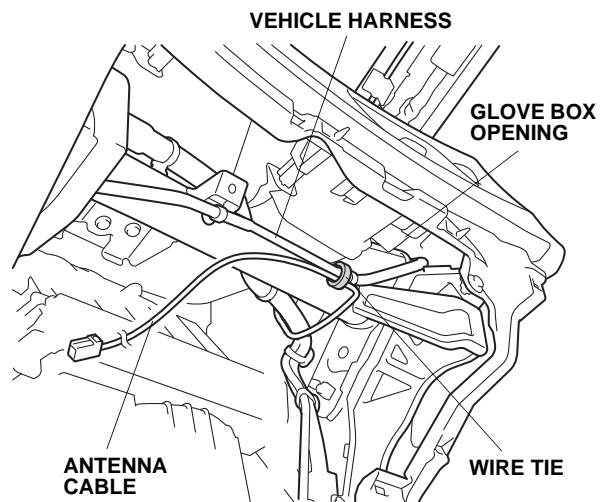

36. Route the antenna cable through the glove box opening and toward the center panel.

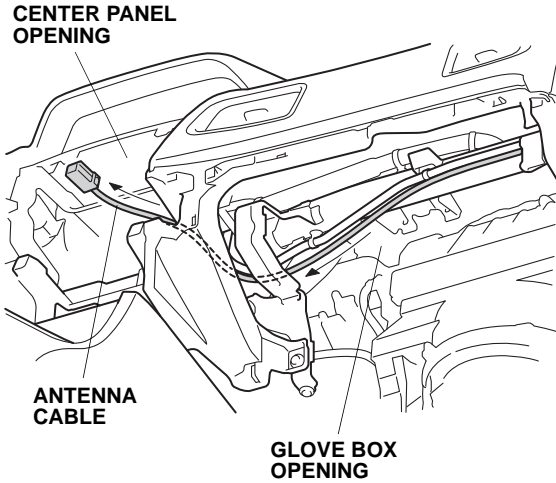

37. Route the antenna cable out the center panel opening, and align it with the other vehicle connector.

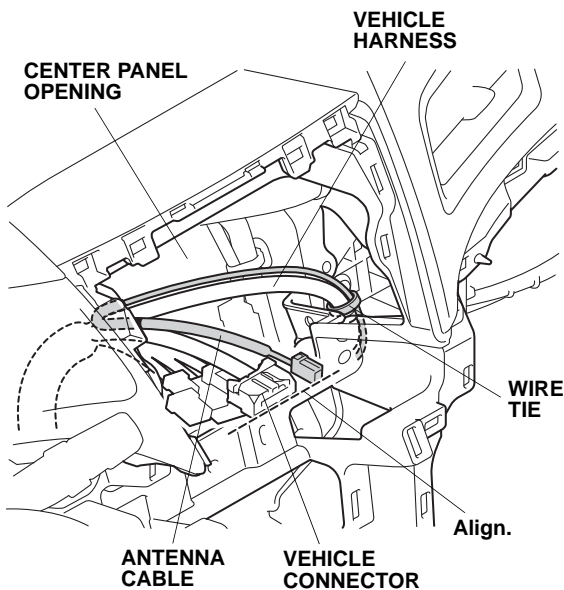

38. Using one wire tie, secure the antenna cable to the vehicle harness inside the center panel.

39. Inside the glove box opening, bundle the excess antenna cable, and secure it to the vehicle harness with two wire ties.

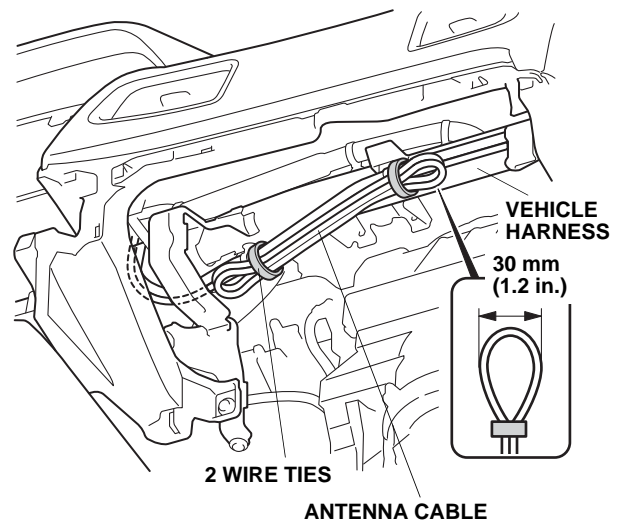

40. Plug the 2-port subharness connector to the vehicle connector.
41. Plug the antenna cable connector to the XM radio unit.
42. Plug the vehicle connectors to the audio unit, and reinstall the center panel.
43. Check that all wire harnesses are routed properly and all connectors are plugged in.
44. Check the overlap between the headliner and the passenger's A-pillar trim. Refer to the service manual. If necessary, adjust the overlap.
45. Reinstall all removed parts.
46. Connect the negative cable to the battery and check the operation of all lights and electrical accessories.
47. Press and hold the radio power button for two seconds to restore radio and navi (if equipped) system functions.
48. Reset the clock on vehicles without navigation.
49. Check the operation of the XM radio system according to the Accessory User's Information Manual.
50. If the IMA battery level gauge is at zero, start the engine and hold the rpm between 3500 and 4000 (no load) in P or N position until the Charge/Assist meter indicates the IMA system has stopped charging the battery.